

Materials and specifications are subject to change without prior notice. Featured machines in photos may include additional equipment.  
Copyright 2022 SANY all rights reserved



Quality Changes the World

# REACH STACKER



Quality Changes the World



SANY Industrial Park, Gaolan Port Economic and Development Zone,  
Zhuhai, Guangdong, China

Tel +86-756-7266963 Service +86-4008-87-8318

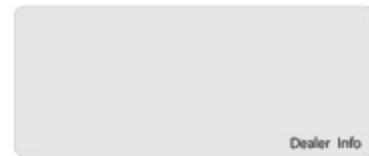

© Printed in China Code: 2011-SMH

[www.sanyglobal.com](http://www.sanyglobal.com)

# SANY REACH STACKER ACHIEVEMENT OF PROFESSIONAL QUALITY

PRODUCT SERIES

01

SAFE AND RELIABLE

03

HIGH-EFFICIENCY

05

ENERGY-SAVING

07



# FULL RANGE OF PRODUCTS

## Enjoy the World Class Performance from China's No.1 Logistics Equipment Supplier

SANY Reach Stacker has been used in ports, wharfs and storage yards to handle, transfer and stack various container and other materials. It features inbuilt functions in safe, reliable, and energy saving with world-leading technologies such as dynamic anti-rollover protection, anti-collision of the spreaders, vertical lift of the booms, patented technology of power driven counterweight and automatic fire extinguisher.

With our full product line up of heavy, overweight hurdling, light, empty container and off-road reach stackers, SANY Reach Stacker can be your solid partner in logistics, energy, chemical engineering, wind power and forestry, bringing you the peace of mind while getting the most out of the job site.



## SAFE AND RELIABLE

Jointly Designed by China and Germany,  
Excellent Quality Assured

### 1 Anti-Rollover Protection

Adopt intelligent control technology, detect real-time working condition and control traveling speed with the changing height of load to prevent the rollover.

### 2 Anti-Collision Protection of the Spreaders while Revolving

Intelligent control of the positions of spreaders and booms can effectively prevent collision among the spreader, frame and boom, avoiding accidents by wrong operation and significantly reducing the working intensity.

### 3 Automatic Fire Extinguisher

The pipeline network automatic fire extinguisher comes with the strong spray can activate the fire alarm, anti-flaming and fire extinction functions to ensure the safety of the operator.

### 4 Solid Tire Flexible Shock Absorption Technology

Provide solid tyre flexible damping system according to customers' needs to achieve safer operation and lower maintenance cost. Combined with flexible shock absorption technology, it significantly reduced the shocking load, raised operation comfort and extended the service life of the components.

### 5 Automatic Braking Technology while Reversing

Adopting technologies such as laser scanning and graphic identification, the reach stacker can precisely detect people or obstacles within the driving route and then automatically brakes to prevent accidents. It is highly intelligent with active safety.

### 6 Advanced Structure Design

Jointly designed by the technical teams from China and Germany, the equipment is assured to be highly reliable and durable by adopting full-digital prototype design system, going through FEA, dynamics simulation analysis, as well as strict endurance and vibration tests.

### 7 Reliable Power System

Equipped with world famous engines such as VOLVO and CUMMINS which are quite reliable, and have strong power, combining the advanced power matching and control technology, the equipment is greatly optimized in dynamic performance. Multiple protections for engine and gearbox: scientifically protect the engine's start-stop, operation and gearbox shifting to extend its service life.



# HIGH-EFFICIENCY

## 1 Boom Vertical Lifting Technology

The intelligent controller detects the boom parameters in real time, automatically calculates and adjusts the boom posture, ensures the vertical lifting throughout the operation, makes stacking safer, and greatly improves work efficiency.

## 2 Efficient Control

The centralized operating handle has excellent micro-motion performance, and easily realizes millimeter-level precise control; all movements of the spreader adopts proportional control, giving you a man-machine integrated operation experience; the whole machine has a multi-action linkage design to achieve fast and efficient operation.

## 3 Comfortable Operation

The operator-oriented design includes an all-round visibility for different working conditions. The controlling devices are placed in designated positions to ease the fatigue of operators.

## 4 Bulk Container Loading and Unloading Technology

Reach stacker for bulk container loading and unloading was developed, which broke through the bottleneck of bulk container handling technology, simplified the process of container loading and unloading, and greatly improved operation efficiency and environmental performance.



## ENERGY-SAVING

- 1 Hydraulic Load Sensing System**  
Automatically adjust the pump displacement according to the load, realizing high precision flow control. The effect of energy saving and consumption reduction is remarkable.
- 2 Dynamic Power Matching Control System**  
Automatically recognize dynamic power according to load change and adjust engine speed. The output power automatically adjust to load and work conditions, greatly reducing energy consumption.
- 3 Lightweight Design**  
Optimize the structure to make it lighter and stronger.



# SRSC45E

## All-Electric Reach Stacker



Scan for Demo



Scan for VR

### 1 Long Battery Life

#### Self-power supply

When the battery cannot be charged, the range extender can be turned on to ensure that the electric reach stacker can work for 20 hours.

#### Energy-saving recycling

With potential energy recovery technology, the descending process can feed back electrical energy to improve battery life.

#### High efficiency and low consumption

Optimized design of hydraulic system, low pressure loss, direct motor drive, high efficiency.

### 2 High Efficiency

#### Precise control

The motor drives the electronically controlled pump system, the action flow can be accurately distributed, and the action control is more precise.

#### Excellent linkage

Boom stretching and hoisting, spreader action and moving are driven by different motors, and the linkage effect is good.

#### Comfortable driving

The driving is directly driven by dual motors, with fast acceleration response, stepless speed regulation, no shift shock, and easy operation.

### 3 Fast Charging

#### Dual gun charging

The product retains the dual-gun charging port, which meets the national standard: GBT 20234.1-2015

Through the market numerous verification, technology is mature and reliable. high-power fast charging, convenient for customers to deploy equipment.



### 4 Cost Saving

Save RMB 197,000 within 1 Year

Save RMB 985,000 within 5 Years

(Under mixed operating conditions with activated range extender)

### Configuration Parameter

Configuration		Unit	SRSC45E
Power Battery	Type	—	Lithium Iron Phosphate
	Capacity	Ah	456
	Rated Storage Energy	kWh	268.7
	Nominal Voltage	V	589.26
	Thermal Management Way	—	Heat: Heating film Cooling: Liquid Cooling
	Max Continuous Discharge Power	KW	268
Motor	Type	—	Permanent Magnet Synchronous Motor
	Output Torque ( Rated/Peak )	Nm	1860/4000
	Output Power ( Rated/Peak )	KW	210/400
	Output Rotate Speed ( Rated/Peak )	RPM	1078/3500
	Cooling Method	—	Liquid Cooling
Range Extender	Drive Axle	—	
	FISG Motor Power	KW	75
	Cooling Method	—	Liquid Cooling
	Engine Power	KW	92
Emission Standard			Comply with GB20891-2014 Stage IV Emission Limit Requirements

## NEW V – SHAPED FRONT LIFT

### Nine Core Advantages

- Configurable imported 5-speed automatic transmission: proportional shift gears, smoother shifting, good comfort and better power performance after matching with the engine.
- Equipped with Sany's new generation hydraulic energy-saving system, combined with engine load precise control system, the energy-saving mode saves 15% fuel under testing conditions.
- Equipped with spreader proportional hydraulic system, with micro-control to improve the box operation.
- Equipped with higher air intake and air intake pre-filter, long air filter life, engine is safer, equipped with ring fire extinguisher, reversing radar, reversing rear view system, safer to use.
- Distributed control system: excellent operation action response, reduced from 800ms to 400ms CAN bus layout, bus buttons, electric proportional handle, higher reliability.
- Classic square section boom
- The wide-section frame and H-type spreader have passed the high-strength fatigue test.



### Highlighted Features

01

#### Energy saving

Fuel consumption under testing conditions is reduced by 15% compared to the original model  
Equipped with high intake pre-filter, long life of filter element and low maintenance cost;  
The whole vehicle LED energy-saving lamp has a longer life;

02

#### Efficiency

Comprehensive work efficiency increased by 10%;  
Full proportional control: more sensitive control and faster response;

03

#### Reliability

After over 10 years' R&D, the quality is excellent;  
30,000 hours fatigue test of structural parts;  
Ring automatic fire extinguishing system;



# LOAD CAPACITY DIAGRAM

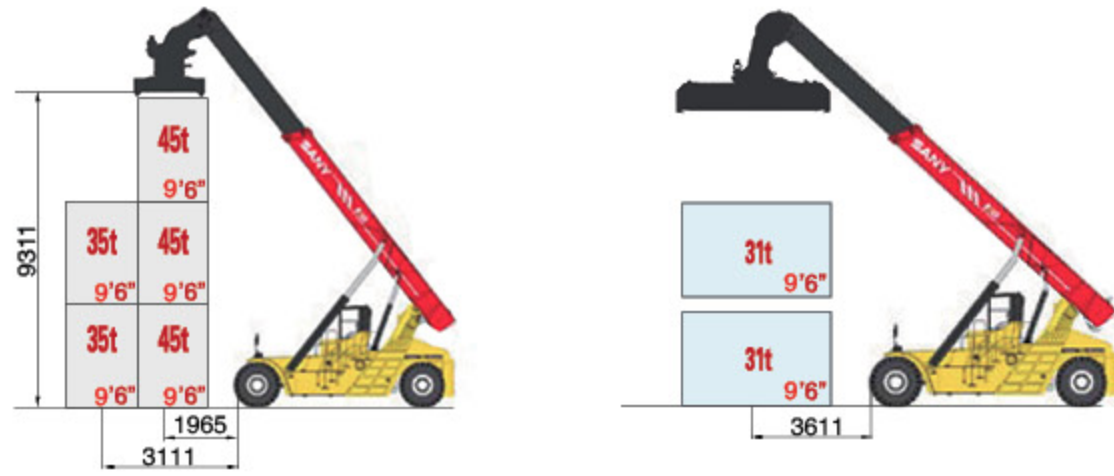

SRSC45T SERIES  
CONTAINER REACH STACKER

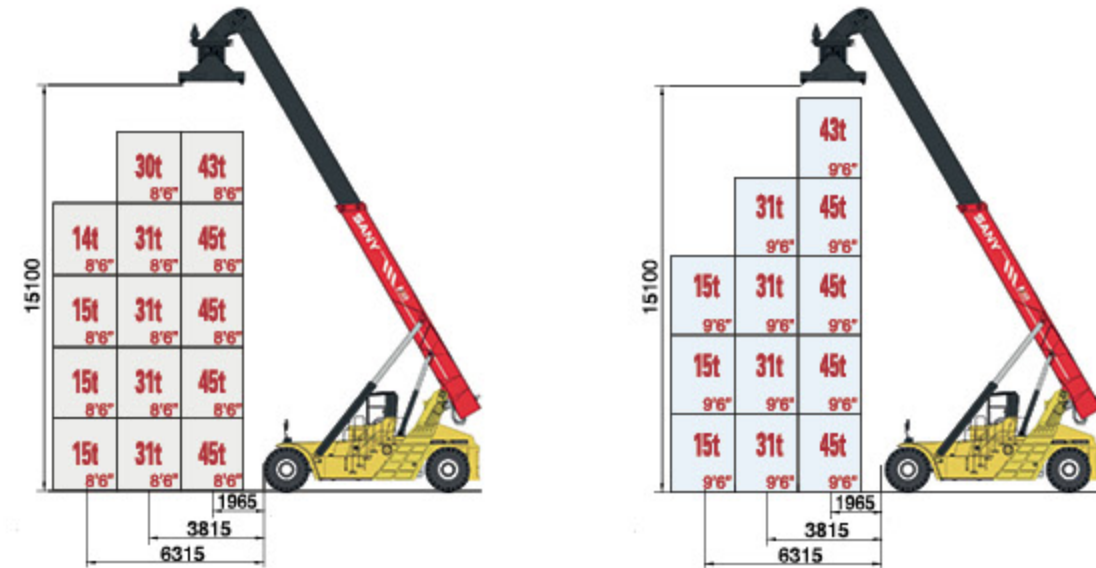

SRSC45E/SRSC45V/SRSC45H/SRSC45GC SERIES  
CONTAINER REACH STACKER

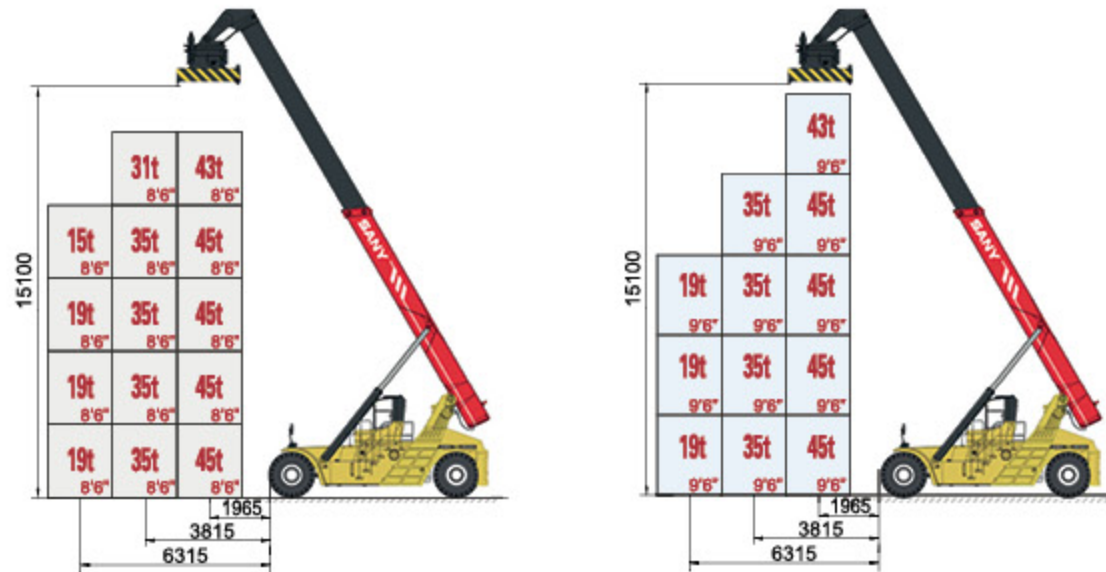

SRSC4535H SERIES HEAVYWEIGHT  
CONTAINER REACH STACKER

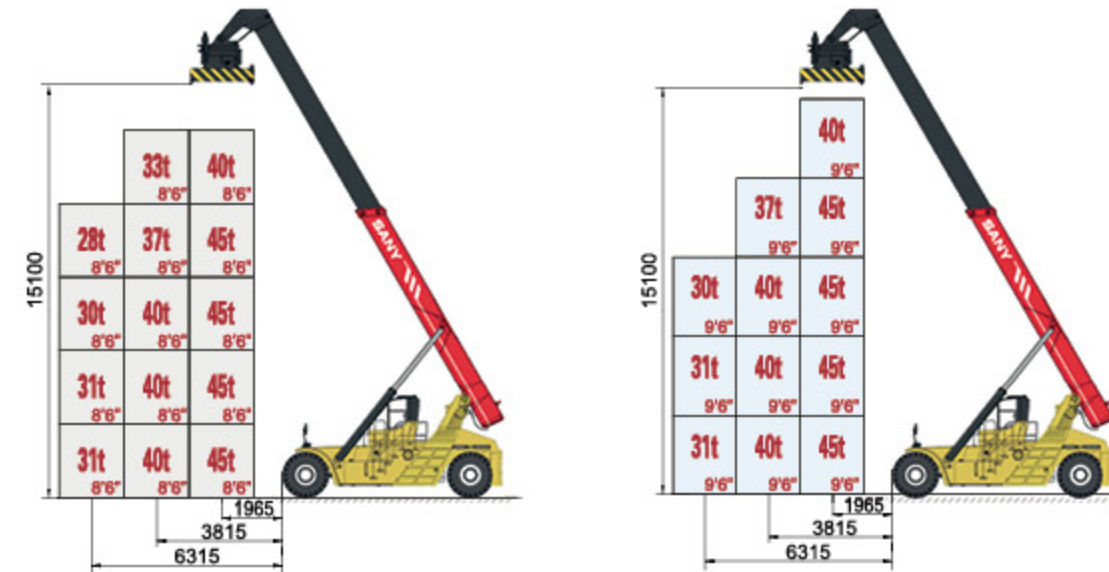

SRSC4540H SERIES HEAVYWEIGHT  
CONTAINER REACH STACKER

# LOAD CAPACITY DIAGRAM

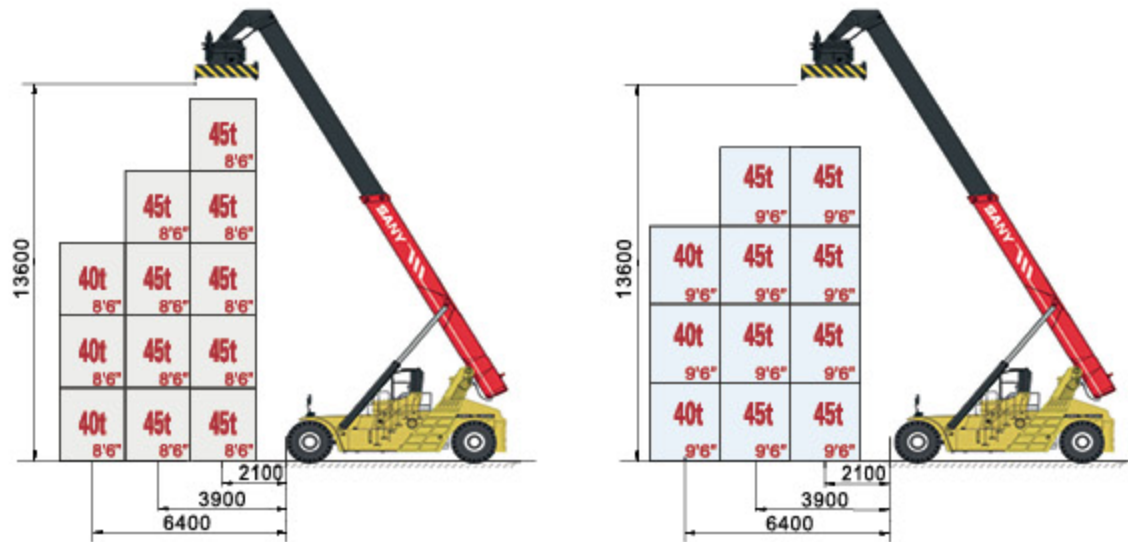

SRSC4545H SERIES OVERWEIGHT  
CONTAINER REACH STACKER

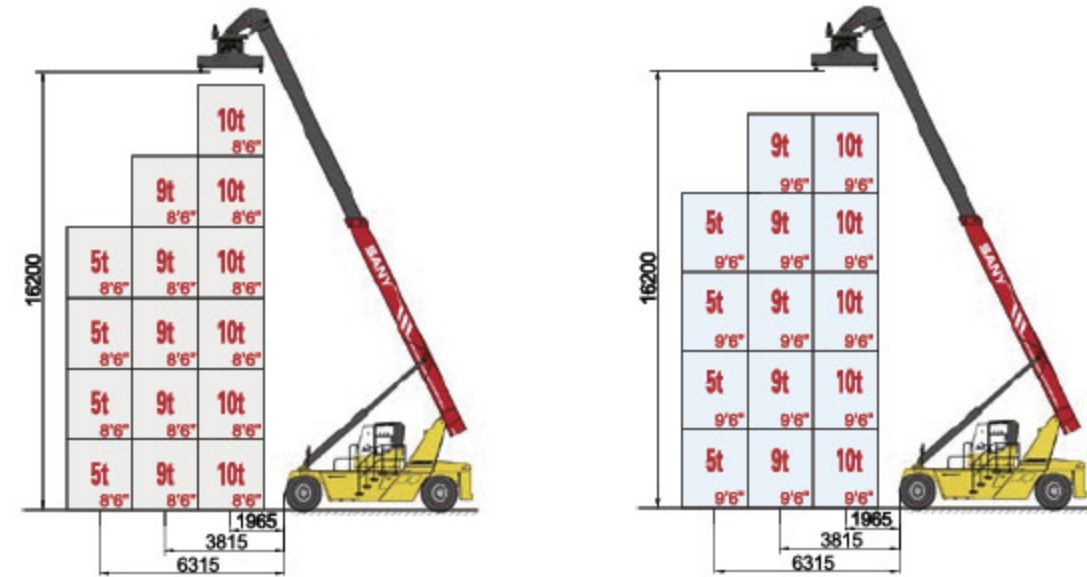

SRSC1009-6E EMPTY  
CONTAINER REACH STACKER

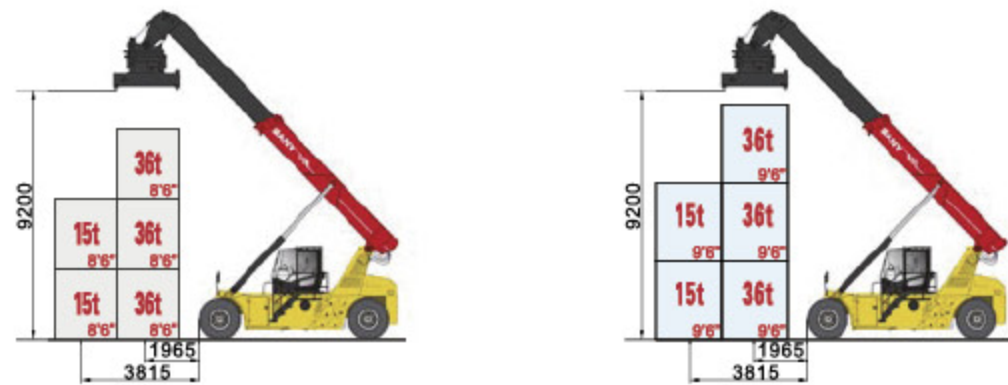

SRSC3615-3 LIGHTWEIGHT  
CONTAINER REACH STACKER

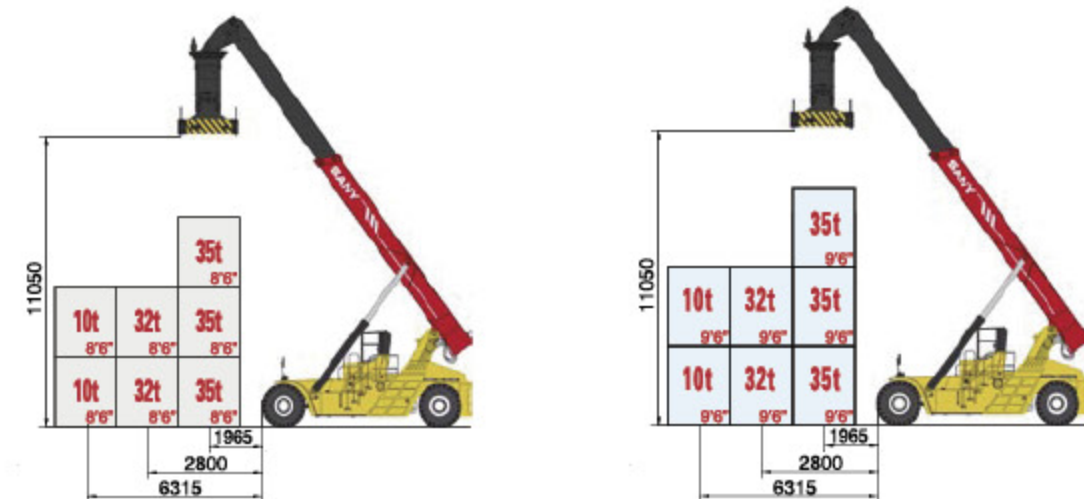

SRSC3532H1-L CONTAINER REACH STACKER  
NOTE: 2800mm just means that the maximum lifting capacity is 32t at this position, not equal to the distance of the container in the second row.



## TECHNICAL PARAMETER

Parameter		Unit	SRSC45H9	SRSC1009-6E	SRSC4535H1	SRSC4535H4-65	SRSC4545H1	SRSC4545H4
engine	model	-	VOLVO TAD1151	CUMMINS QSB 6.7	VOLVO TAD1151	CUMMINS QSL9	VOLVO TAD1151	CUMMINS QSL9
	rated capacity	kW/rpm	265/2100	164/2300	265/2100	248/2100	265/2100	248/2100
	max torque	Nm/rpm	1780/1260	949/1500	1780/1260	1424/1500	1780/1260	1424/1500
	emission standard	-	III	III	III	IV	III	IV
gearbox model		-	DANA 16.7TE30510	DANA 13.7HR32334	DANA 15.5HR36000	DANA 15.7TE32418	DANA 15.5HR36000	DANA 15.7TE32418
axle model		-	SANY	SANY	SANY	SANY	SANY	SANY
spreader	model	-	SDJ450H-R1	SDJ450H-R1	SDJ450H-R1	SDJ450H-R1	SDJ450H-R1	SDJ450H-R1
	shift distance	mm	±800	±600	±800	±800	±800	±800
	slewing angle	deg	+105/-195	+105/-195	+105/-195	+105/-195	+105/-195	+105/-195
	inclination angle	deg	—	—	—	—	—	—
	weight	t	7.2	4.3	7.8	7.8	7.8	7.8
	application	-	ISO20'/40'/45'	ISO20'/40'/45'	ISO20'/40'/45'	ISO20'/40'/45'	ISO20'/40'/45'	ISO20'/40'/45'
boom	max hoisting height	mm	15100	16200	15100	15100	13600	13600
	inclination angle	deg	0~60	0~64.5	0~58	0~58	0~50	0~50
tyre		-	18.00-25 40PR	14.00-24 28PR	18.00-33 36PR	18.00-33 36PR	21.00-35 36PR	21.00-35 36PR
max hoisting speed(unloaded/loaded)		mm/s	420/250	450/400	420/250	420/250	400/220	400/220
max descending speed(unloaded/loaded)		mm/s	360/300	400/400	360/300	360/300	360/280	360/280
max travelling speed(unloaded/loaded)		km/h	25/21	28/25	25/18	25/18	20/15	20/15
gradeability(unloaded/loaded)		%	39/32	33/27	38/24	38/24	26/17	26/17
hydraulic system pressure		bar	260	220	260	260	260	260
overall weight		t	73	39	76.5	76.5	96.5	96.5
rated capacity		t	45	10	45	45	45	45
No. of stack		-	5 (9'6"/8'6")	6 (8'6")	5 (9'6"/8'6")	5 (9'6"/8'6")	5 (8'6")	5 (8'6")
overall length		mm	11340	11000	11845	11845	13270	13270
wheel base		mm	6000	5000	6500	6500	8000	8000
overall height		mm	4770	4000	4870	4870	5230	5230
min ground clearance		mm	350	250	350	350	420	420
overall width		mm	6053-12185	6053-12185	6053-12185	6053-12185	6053-12185	6053-12185
balance weight movable distance		mm	-	-	—	—	—	—
front tyre distance		mm	3033	3280	3033	3033	3060	3060
rear tyre distance		mm	2790	2450	2790	2790	3120	3120
min turing radius		mm	8000	6800	8800	8800	10600	10600
20' container aile width		mm	11300	10000	11600	11600	14500	14500
40' container aile width		mm	13600	13600	13600	13600	15200	15200

## TECHNICAL PARAMETER

Parameter		Unit	SRST50H1-H	SRSC3532H1-L	SRSC4540G5	SRSC4540G5-S	SRSC45G5	SRSC45V1A
engine	model	-	VOLVO TAD1151	VOLVO TAD1151	VOLVO TAD1181VE	VOLVO TAD1181VE	VOLVO TAD1181VE	VOLVO TAD1151
	rated capacity	kW/rpm	265/2100	265/2100	265/2100	265/2100	265/2100	265/2100
	max torque	Nm/rpm	1780/1260	1780/1260	1785/1400	1785/1400	1785/1400	1780/1260
	emission standard	-	III	III	V	V	V	III
gearbox model		-	DANA 15.5HR36000	DANA 15.5HR36000	DANA 157TE30510-7	DANA 157TE30510-7	DANA 157TE30510-7	DANA 15.7TE30510
axle model		-	SANY	SANY	SANY	SANY	SANY	SANY
spreader	model	-	SDJ400G1	SDJ5320D	SDJ450G	SDJ450G	SDJ450G	SDJ450H-R1
	shift distance	mm	-	+1000/-600	±800	±800	±800	±800
	slewing angle	deg	360	+105° /-195°	+105/-195	+105/-195	+105/-195	+105/-195
	inclination angle	deg	—	55°	-	-	-	—
	weight	t	1.2	7.5	7.8	7.8	7.8	7.15
	application	-	-	ISO20'	ISO20'/40'/45'	ISO20'/40'/45'	ISO20'/40'/45'	ISO20'/40'/45'
boom	max hoisting height	mm	15000	13910	15100	15100	15100	15100
	inclination angle	deg	0~60	0 ~ 60	56.5	56.5	60	0~60
tyre		-	18.00-25 40PR	18.00-25 40PR	18.00-33 36PR	18.00-33 36PR	18.00-25 40PR	18.00-25 40PR
max hoisting speed(unloaded/loaded)		mm/s	420/250	420/250	420/250	420/250	420/220	420/250
max descending speed(unloaded/loaded)		mm/s	360/300	360/300	360/300	360/300	500/400	360/300
max travelling speed(unloaded/loaded)		km/h	25/21	25/21	25/21	25/21	25/21	25/20
gradeability(unloaded/loaded)		%	39/32	39/32	43/28	43/28	46/28	39/32
hydraulic system pressure		bar	260	260	260	260	280	280
overall weight		t	65.5	72	81.5	83.5	72.5	71
rated capacity		t	50	35	45	45	45	45
No. of stack		-	-	4(9'6"/8'6")	5 (9'6"/8'6")	5 (9'6"/8'6")	5 (9'6"/8'6")	5 (9'6"/8'6")
overall length		mm	10580	11390	12291	12291	11290	11320
wheel base		mm	6000	6000	7000	7000	6000	6000
overall height		mm	4770	4770	4940	4940	4850	4950
min ground clearance		mm	350	350	350	350	330	350
overall width		mm	4188	6053	6052	6052	4188	6053-12185
balance weight movable distance		mm	-	-	-	-	-	-
front tyre distance		mm	3033	3033	3033	3033	3112	3033
rear tyre distance		mm	2790	2790	2790	2790	2790	2790
min turing radius		mm	8000	8000	9100	9100	8000	8000
20' container aile width		mm	-	11300				11300
40' container aile width		mm	-	-				13600

## TECHNICAL PARAMETER

Parameter		Unit	SRSC45E	SRSC4540H4	SRSC45G59	SRSC4535G5	SRSC4535G5-S	SRSC4540G5-75
engine	model	-	YC075ZQ-1(357501)	QSL9 261kw Tier4F	VOLVO TAD1181VE	VOLVO TAD1181VE	VOLVO TAD1181VE	VOLVO TAD1181VE
	rated capacity	kW/rpm	92/2200	248/2100	265/2100	265/2100	265/2100	265/2100
	max torque	Nm/rpm	500/1300~1600	1424/1500	1785/1400	1785/1400	1785/1400	1785/1400
	emission standard	-	IV	IV	V	V	V	V
gearbox model		-	-	DANA 15.7TE32418	DANA 157TE30510-7	DANA 157TE30510-7	DANA 157TE30510-7	DANA 157TE30510-7
axle model		-	SANY	SANY	SANY	SANY	SANY	SANY
spreader	model	-	SDJ450H-R1	SDJ450H-R1	SDJ450H-R1	SDJ450G	SDJ450G	SDJ450G
	shift distance	mm	±800	±800	±800	±800	±800	±800
	slewing angle	deg	+105/-195	+105/-195	+105/-195	+105/-195	+105/-195	+105/-195
	inclination angle	deg	-	-	-	-	-	-
	weight	t	7.15	7.8	7.2	7.8	7.8	7.8
	application	-	ISO20'/40'/45'	ISO20'/40'/45'	ISO20'/40'/45'	ISO20'/40'/45'	ISO20'/40'/45'	ISO20'/40'/45'
boom	max hoisting height	mm	15100	15100	15100	15100	15100	15100
	inclination angle	deg	0~60	0~57	0~60	0~58	0~58	56.5
tyre		-	18.00-25 40PR	18.00-33 36PR	18.00-25 40PR	18.00-33 36PR	18.00-33 36PR	18.00-33 36PR
max hoisting speed(unloaded/loaded)		mm/s	420/250	420/250	420/250	420/250	420/250	420/220
max descending speed(unloaded/loaded)		mm/s	360/300	360/300	360/300	360/300	360/300	360/300
max travelling speed(unloaded/loaded)		km/h	21/15	22/16	25/21	25/21	25/21	25/21
gradeability(unloaded/loaded)		%	28/16	27/18	39/32	43/26	43/26	38/23
hydraulic system pressure		bar	280	260	260	260	260	260
overall weight		t	71	89	73	76.5	76.5	88
rated capacity		t	45	45	45	45	45	45
No. of stack		-	5 (9'6"/8'6")	5 (9'6"/8'6")	5 (9'6"/8'6")	5 (9'6"/8'6")	5 (9'6"/8'6")	5 (9'6"/8'6")
overall length		mm	11320	12329	11340	11860	11860	12790
wheel base		mm	6000	7000	6000	6500	6500	7500
overall height		mm	4950	4362	4770	4880	4880	5010
min ground clearance		mm	372	350	350	350	350	350
overall width		mm	6053-12185	6053-12185	6053-12185	6053-12185	6053-12185	6052
balance weight movable distance		mm	-	-	-	-	-	-
front tyre distance		mm	3033	3060	3033	3033	3033	3033
rear tyre distance		mm	2790	3120	2790	2790	2790	2790
min turing radius		mm	8000	9500	8000	8600	8600	9700
20' container aile width		mm	11300		11300	11600	11600	
40' container aile width		mm	13600		13600	13600	13600	

## ATTACHMENT OPTIONS

### 45t Container Spreader

SANY 45T container spreader is used in reach stacker to stack, load or unload ISO standard 20', 40' and 45' containers. Based on market needs, Sany Port Machinery has developed numerous container spreaders of reasonable structure with good design, strong safety protection function and cost effective, sufficiently meeting different requirements of the customers.

**SDJ450H:** New model of spreader, light weight design, more energy saving and lower fuel consumption  
 Rated capacity: 45t  
 Application: ISO 20'/40'/45' Containers



### F Model Spreader SDJ450F

Rated capacity: 45t  
 Application: ISO 20' /40' /45' Containers



### Empty Container Spreader

SANY SDJE100 spreader is applicable to the transfer and stacking of ISO standard 20', 40' and 45' container or refrigerator. It is the first of this kind spreader in China. Flexible, convenient and economic, it will be your best choice.

**SDJE100H:** Empty container stacking, flexible and convenient  
 Rated capacity: 10t  
 Application: ISO 20' /40' /45' Containers



### Combined Spreader

SANY SDJE450P spreader is applicable to the transfer and stacking of ISO standard 20', 30', 35', 40' and 45' container and the transfer of EN284 non-stacking container. It has multiple usages, which meet the European and American intermodal working mode requirements.

**SDJ450P:** Workable at multi-conditions, quick response to container-aligning operation  
 Rated capacity: 45t  
 Application: ISO 20' /30' /35' /40' /45' Containers  
 EN284 non-stacking containers



### Log Spreader

SANY SWG310 spreader is applicable to transfer, load and unload log or other special materials. This product has perfectly solved the difficulty of transporting and loading specific materials such as log, bringing high profit for customers

**SWG310-R3:** Highly efficient log grabs  
 Rated capacity: 31t Application: wood



### Tilt Spreader

SANY SDJS320 spreader is designed for Reach Stacker to transport, unload container bulk materials. This product has perfectly solved the difficulty of transporting and unloading bulk materials. It fills in the domestic blank, breaks through the bottleneck of unloading bulk materials, and highly improves the efficiency and environment-protection performance.

**SDJS320D:** A born bulk cargo handling expert  
 Rated capacity: 35t Tilt angle: 0~55°  
 Application: ISO 20' Containers

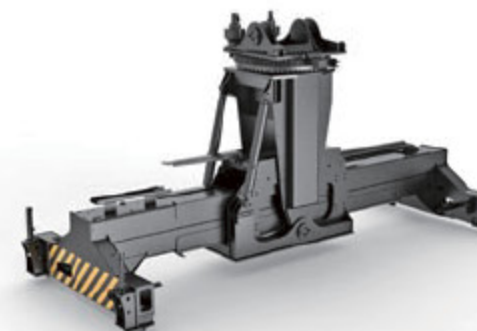

### Tube Spreader

SANY tube spreader applies to transfer and hoisting not only tube and pipe like material, but also container or bulk cargo.

**STP450**  
 Rated capacity: 45t  
 Application: Pipeline



**SDJ400G**  
 Rated capacity: 40t  
 Application: Large tube, bulk cargo



ALL FOR CUSTOMERS,  
 ALL FROM INNOVATION

## ADD-ON OPTIONS

Function	Brand	Code	Note
Cab Reading Light	SANY	11446638	Mounted on the top of the cab
Light for the top of cab	SANY	13206545	Install 4 lights on the top of the cab to enhance the lighting in front of the cab
Rear counterweight warning light	SANY	14024064	Installed on the rear counterweight
Heat preservation device for extremely cold district	SANY	13816251	Only suitable VOLVO TAD1151 engine Use in North America, Russia, Europe, etc., where the temperature is lower than -30°C, use heating methods of external power supply
Heat preservation device for extremely cold district	SANY	14105615	Only applicable to Cummins QSL9 IV stage engine Voltage 110V, used in North America, South Korea and other regions. using external power supply heating method
Heat preservation device for normal cold district	SANY	13816342	It is mainly used in the cold district in China. It is recommended for district where the temperature is below -5° C. It is a must for district where the temperature is below -15° C.
Spreader twist lock counter	SANY	11446031	Spreader twist lock counter meter
Engine hour meter	SANY	11446498	Hour meter for the engine's working hours
Amplifying alarm system	SANY	11447670	Including the amplifier and the alarm
3m range reversing radar system	SANY	61024888	Including 6 radar probes +1 camera +1 pcs 7-inch independent display, Detection distance 3 meters
5m range reversing radar system	SANY	61024886	Including 6 radar probes +1 camera +1 pcs 7-inch independent display, Detection distance 5 meters
Radio	SANY	13206553	Including radio, speaker and antenna.

Function	Brand	Code	Note
precise weighing, unbalance load detection system	SANY	14313665	Used for Sany 450FA spreader, including 7-inch display, with weighing, unbalance load detection, and printing system
Driving recorder	SANY	14105126	Installed in the cab, the main monitoring operation, including: 7-inch LCD screen + camera + built-in 64G (expandable to 256G)
Spreader and rear counterweight camera system	SANY	14004430	Including: spreader 4 cameras, 3 meters reversing radar and reversing camera (F type spreader)
Spreader and rear counterweight camera system	SANY	14249848	Including: spreader 4 cameras, 3 meters reversing radar and reversing camera (H type spreader)
Car walkie-talkie	SANY	14105115	Digital walkie-talkie
Handheld walkie-talkie	SANY	60293871	Handheld digital walkie-talkie
Tyre monitor system	SANY	60250623	Used to monitor the tyre pressure of reach stacker
Light and heavy box selection function	SANY	14138719	The light and heavy container mode is selected through two rocker switches, to prevent incorrect container loading, and to prevent the train skins from being lifted when unloading.
Hydraulic emergency system	SANY	14318160	After the conventional hydraulic system fails, this system can realize the boom telescopic, pitch, steering axle selection, and spreader unlocking
Container weighing, voice broadcast function	SANY	14475499	Real-time broadcast of container weight during hoisting
Cab assistant seat	SANY	12774971	Cab assistant seat
Alarm lock	SANY	130907000020	It will alarm, when the seat belt is not fastened



# Shots from the Jobsites



Taicang Port, Jiangsu



Empty Reach Stacker, Bangladesh



Tilt Reach Stacker, Jiangsu



Xinjiang



India



Kuantan, Malaysia



Qingdao Port



Tower Cylinder Reach Stacker, Inner Mongolia



Cross Track Reach Stacker, Australia



Sanitation Reach Stacker, Chongqing



Luanda Port, Angola



Explosion Rescue, Tianjin Port



Libya



Reach Stacker used for planes, Indonesia

# SERVICE

## Carefree Service



品质改变世界 服务创造价值  
Quality Changes the World Service Creates value

Support Service: **+86-4008-87-8318**

### Service vision:

Exceed customer expectation and industry standards.

### Service mission:

All for client, create value for customer

### Service commitment:

- (1) Reply customer within 15 minutes.
- (2) Reach main service area within 2 hours.
- (3) Solve general problems and provide regular parts within one day.
- (4) Solve customer complaints with two days.
- (5) Solve all issues within 7 days.

### Service value:

Innovation、Excellence、Clients、Cooperation、Respect、Passion、Honesty、Responsibility

### Service advantage:

“Professional service power” : Sany has offices in over 200 countries and regions, with 11 subsidiaries and 35 service points in domestic together. Setting up the parts warehouse can cover the world range, Forming the four in one of parts supply and guarantee system by headquarters warehouse, regional center warehouse, provincial and prefecture-level city, Accommodating 80000 kinds of parts to ensure fully customer service requirements in time.

“Professional operation and maintenance system” : Sany has invested tens of million of RMB to build “Sany Customer cloud APP” ,which enable customers to monitor the running status and parameters of the equipment in real time anywhere in the world. In addition, it provides online consultation, community communication, accessories mall, one-click repair, maintenance reservation, product knowledge learning and other value-added service. So the customer can easily enjoy the highest quality of service in any place of the world.

